



Technical Data Sheet

June 2018

V1001V

INTERNATIONAL MASTER
FOR PROFESSIONAL USE ONLY

TURBO VISION® Premium High Flow Pluralmix Topcoat

<i>Product</i>	<i>Description</i>
P650-1001	Premium High Flow Pluralmix Binder
P600-9xxx	Coloured Tinters
P210-7604	EHS Plural Mix Hardener - Medium

Product Description

Turbo Vision Premium High Flow Pluralmix Topcoat has been optimised for Commercial Transportation Vehicles for both builders.

Turbo Vision Premium High Flow Pluralmix Topcoat is an easy to spray topcoat providing high opacity, outstanding gloss and general appearance with long term durability, which fully meets the highest standards demanded by fleet market.

Turbo Vision Premium High Flow Pluralmix Topcoat can be baked at low temperature or left airdry.

THESE PRODUCTS ARE FOR PROFESSIONAL USE ONLY.

Nexa Autocolor and design and *Turbo Vision* are registered trademarks of PPG Industries Ohio, Inc.
© 2018 PPG Industries, Inc. All rights reserved.

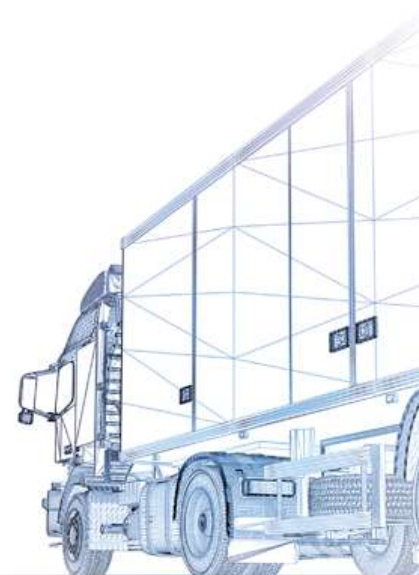

TURBO VISION®



Substrates and Preparation

Prepare the Substrate as follows:

Substrates:

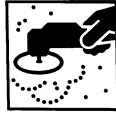

- Original finishes and work in sound condition need to be degreased, cleaned and dry sanded with P320-P400 or (P600 wet) prior to topcoat application.
- Steel, Aluminum, GRP & Zinc coated steel need to be primed with the appropriate primer in order to ensure correct intercoat adhesion and substrate protection.
- TURBO VISION® Premium High Flow Pluralmix Topcoat is suitable over all Nexa Autocolor primers, surfacers and sealers.

Cleaning:



The substrate to be painted must be dry, clean, free of corrosion, grease & mould release agents.

Substrates need to be thoroughly wiped using the appropriate degreaser (P850-1367 Degreaser & P850-1378 Spirit Wipe or P980-9010 low V.O.C cleaner)

Process

Conventional, Pressure Pot or Air Assisted Airless Application

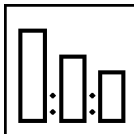

Mixing Ratio by Volume:

<i>Turbo Vision</i> Premium High Flow Pluralmix Topcoat	1
P210-7604 pluralmix hardener	1



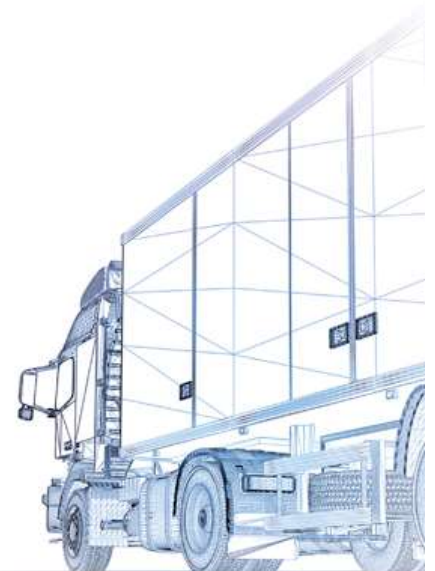

THESE PRODUCTS ARE FOR PROFESSIONAL USE ONLY.

Nexa Autocolor and design and Turbo Vision are registered trademarks of PPG Industries Ohio, Inc.
© 2018 PPG Industries, Inc. All rights reserved.

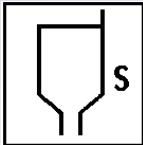
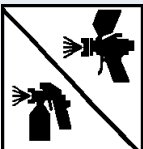

TURBO VISION®

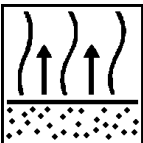

Process							
Conventional, Pressure Pot or Air Assisted Airless Application							
	Spray Viscosity at 20°C: 18-22 seconds DIN4						
	1,3-1,5 mm Gravity or suction feed at 2.0-2,4 bars						
	OR 0,8-1mm Pressure Pot Air Cap Pressure: 0.68 bar Paint Pressure : 0.3-1.0 bar Fluid flow rate: 280-320 cc/min						
	OR Tip Size: 9 to 11 Thou (0,23 to 0,28 mm) for Air Assisted Airless Paint Pressure: 90-110 bars Air Atomization: 2,5-3 bars						
Number of Coats							
	<table border="0" style="width: 100%;"> <tr> <td style="text-align: center;"><u>1 Visit:</u></td> <td style="text-align: center;"><u>2 coats:</u></td> </tr> <tr> <td style="text-align: center;">1 light coat + 1 Full coat</td> <td style="text-align: center;">1 Medium closed + 1 Full coat</td> </tr> </table>	<u>1 Visit:</u>	<u>2 coats:</u>	1 light coat + 1 Full coat	1 Medium closed + 1 Full coat		
<u>1 Visit:</u>	<u>2 coats:</u>						
1 light coat + 1 Full coat	1 Medium closed + 1 Full coat						
Dry Film Thickness:	<table border="0" style="width: 100%;"> <tr> <td style="text-align: center;">50 – 60 µm</td> <td style="text-align: center;">50 – 70 µm</td> </tr> </table>	50 – 60 µm	50 – 70 µm				
50 – 60 µm	50 – 70 µm						
	<table border="0" style="width: 100%;"> <tr> <td style="text-align: center;"><u>1 Visit:</u></td> <td style="text-align: center;"><u>2 coats:</u></td> </tr> <tr> <td style="text-align: center;">Flash-Off between coats:</td> <td style="text-align: center;">2-3 minutes</td> </tr> <tr> <td style="text-align: center;">Flash-Off before bake:</td> <td style="text-align: center;">10 minutes</td> </tr> </table>	<u>1 Visit:</u>	<u>2 coats:</u>	Flash-Off between coats:	2-3 minutes	Flash-Off before bake:	10 minutes
<u>1 Visit:</u>	<u>2 coats:</u>						
Flash-Off between coats:	2-3 minutes						
Flash-Off before bake:	10 minutes						

THESE PRODUCTS ARE FOR PROFESSIONAL USE ONLY.

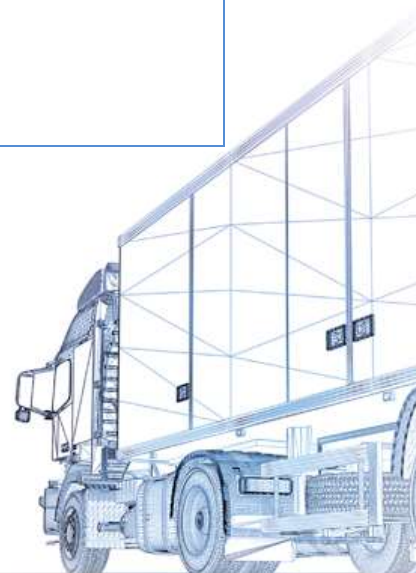

TURBO VISION®



Colour

COLOUR MIXING

All Tinters should be thoroughly hand stirred when first opened, and then stirred on a mixing machine for 10 minutes before use. Thereafter all tinters should be machine stirred twice a day for at least 10 minutes.

COLOUR CHECKING

As with all refinish paint systems, a colour check should be carried out before painting the vehicle.

General Process Notes

DECAL APPLICATION

It is recommended that TURBO VISION® Premium High Flow Pluralmix Topcoat is allowed to cure for at least one week prior to any decal application.

COVERAGE

Approximately 12 to 13 m² per litre of ready for use paint at a dry film thickness of 50 microns depending on thinning ratio used.

OTHER POINTS TO NOTE

Allow finishes to harden thoroughly before subjecting to vehicle washes. This can take a number of weeks if vehicles are air-dried in cold conditions and/or paint film thickness is excessively high.

VOC INFORMATION

The EU limit value for this product (product category: IIB.d) in ready to use form is max. 420g/litre of VOC. The VOC content of this product in ready to use form is max. 420g/litre. Depending on the chosen mode of use, the actual ready to use VOC of this product may be lower than that specified by the EU Directive code.

THESE PRODUCTS ARE FOR PROFESSIONAL USE ONLY.

Nexa Autocolor and design and Turbo Vision are registered trademarks of PPG Industries Ohio, Inc.
© 2018 PPG Industries, Inc. All rights reserved.

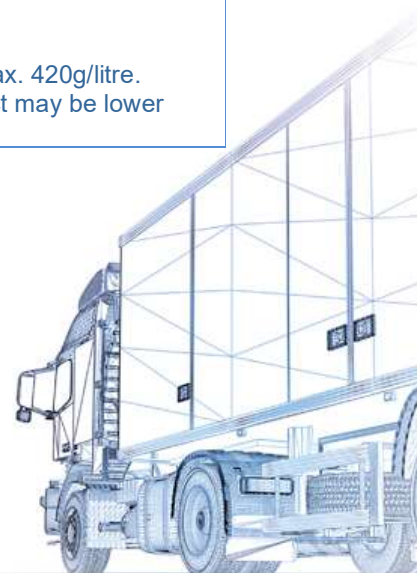

TURBO VISION®



These products are for professional use only, and are not to be used for purposes other than those specified. The information on this TDS is based on present scientific and technical knowledge, and it is the responsibility of the user to take all necessary steps in order to ensure the suitability of the product for the intended purpose.

For Health and Safety information please refer to the material Safety Data Sheet, also available at: http://www.ppg.com/Autocolor_MSDS

For further information please contact:

Customer Service Sales Group
PPG Industries (UK) Ltd
Needham Road
Stowmarket
Suffolk IP14 2AD

Tel: 01449 771771

Fax: 01449 773472

THESE PRODUCTS ARE FOR PROFESSIONAL USE ONLY.

Nexa Autocolor and design and *Turbo Vision* are registered trademarks of PPG Industries Ohio, Inc.
© 2018 PPG Industries, Inc. All rights reserved.

