



Technical Data Sheet

V9006V

February 2023

INTERNATIONAL MASTER
FOR PROFESSIONAL USE ONLY

TURBO VISION® RAL9006 Aluminium Ready Mix Topcoat	
Product	Description
P651-9006	RAL9006 Aluminium Ready Mix
P650-6000	Premium Matt Binder
P600-9xxx	Coloured Tinters
P210-7644	EHS Hardener - Standard
P210-7642	EHS Hardener - Slow
P210-7606	EHS Hardener - Pluralmix
P852-6442	EHS Thinner - Slow
P852-6444	EHS Thinner - Medium
P852-6446	EHS Thinner - Fast

Product Description

Turbo Vision RAL9006 Aluminium Topcoat is dedicated for Commercial Transportation Vehicles for both builders and repairers.

Turbo Vision RAL9006 Aluminium Topcoat is an easy to spray topcoat providing good opacity, high gloss and general appearance which meets the standards demanded by the fleet market.

Thanks to the selection of its ancillaries, *Turbo Vision* RAL9006 Aluminium Topcoat:

- can be used from small to large area
- can be sprayed in a large range of temperature conditions

Turbo Vision RAL9006 Aluminium Topcoat is a 2-pack acrylic Single Layer Direct Gloss Metallic Topcoat designed for painting RAL9006 colour in one stage instead of 2.

It doesn't need to be recoated with a clearcoat.

It has to be sprayed in 2 full coats without spraying any control coat.



TURBO VISION®

Substrates and Preparation

Prepare the Substrate as follows:

Substrates:

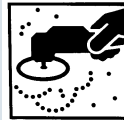

- Original finishes and work in sound condition need to be degreased, cleaned and dry sanded with P320-P400 or (P600 wet) prior to topcoat application.
- Steel, Aluminum, GRP & Zinc coated steel need to be pre-primed with the appropriate primer in order to ensure correct intercoat adhesion and substrate protection.
- TURBO VISION® RAL9006 Aluminium Topcoat is suitable over all NEXA AUTOCOLOR® primers, surfacers and sealers.

Cleaning:



The substrate to be painted must be dry, clean, free of corrosion, grease & mould release agents.

Substrates need to be thoroughly wiped using the appropriate degreaser (P850-1367 Degreaser & P850-1378 Spirit Wipe or P980-9010 low V.O.C cleaner)

Process

Conventional or Pressure Pot

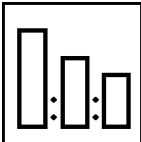

Mixing Ratio by Volume:

<i>Turbo Vision</i> RAL9006 Aluminium Topcoat	3
P210-764X Hardener	1
P852-644X Thinner (*)	1.5

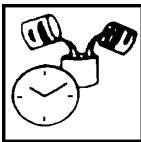

Temperature	<18°C	18-25°C	25-30°C	>30°C
Combination	Medium/ Fast	Medium/ Medium	Medium/ Slow	Slow/ Slow
Ancillaries	P210-7644/ P852-6446	P210-7644/ P852-6444	P210-7644/ P852-6442	P210-7642/ P852-6442



TURBO VISION

Process	
	Conventional or Pressure Pot
	Spray Viscosity at 20°C: 18-23 seconds DIN4
	Potlife @20°C: 3 hours
	1,4-1,5 mm Gravity or suction feed at 2.0-2,5 bars
	OR 0,8-1mm Pressure Pot Air Cap Pressure: 0.5-1 bar Paint Pressure : 0.3-1.0 bar Fluid flow rate: 280-320 cc/min
	Number of Coats <u>2 coats:</u> 1 Full coat + 1 Full coat Dry Film Thickness: 40 – 60 µm
	<u>2 coats:</u> Flash-Off between coats: 15-20 minutes Flash-Off before bake: 15-20 minutes
	Stoving at metal temperature of : 55°C 45 minutes Into-Service When cool

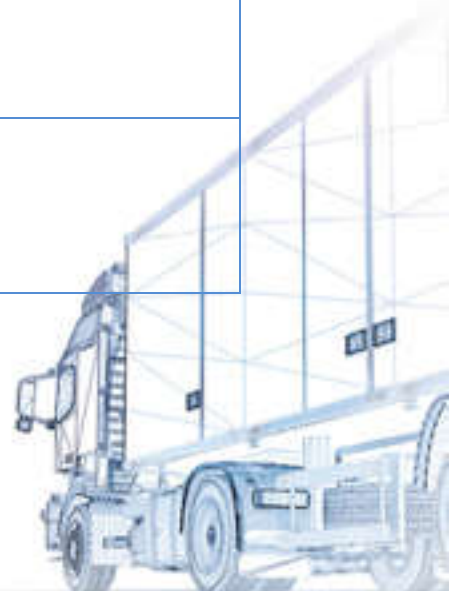

TURBO VISION

Pluralmix Process											
	Conventional or Pressure Pot										
	Prethinning ratio by Volume: <table border="0"> <tr> <td><i>Turbo Vision</i> RAL9006 Aluminium Topcoat</td> <td>7</td> </tr> <tr> <td>P852-644X Thinner (*)</td> <td>3</td> </tr> <tr> <td colspan="2"> </td> </tr> <tr> <td><i>Turbo Vision</i> RAL9006 Aluminium Topcoat</td> <td>3,34 (Pump A)</td> </tr> <tr> <td>P210-7606 Pluralmix Hardener</td> <td>1 (Pump B)</td> </tr> </table>	<i>Turbo Vision</i> RAL9006 Aluminium Topcoat	7	P852-644X Thinner (*)	3			<i>Turbo Vision</i> RAL9006 Aluminium Topcoat	3,34 (Pump A)	P210-7606 Pluralmix Hardener	1 (Pump B)
	<i>Turbo Vision</i> RAL9006 Aluminium Topcoat	7									
P852-644X Thinner (*)	3										
<i>Turbo Vision</i> RAL9006 Aluminium Topcoat	3,34 (Pump A)										
P210-7606 Pluralmix Hardener	1 (Pump B)										
	<table border="1"> <tr> <td>Temperature</td> <td>18-25°C</td> <td>>25°C</td> </tr> <tr> <td>Ancillaries</td> <td>P852-6446 Fast Thinner</td> <td>P852-6444 Medium Thinner</td> </tr> </table>	Temperature	18-25°C	>25°C	Ancillaries	P852-6446 Fast Thinner	P852-6444 Medium Thinner				
	Temperature	18-25°C	>25°C								
Ancillaries	P852-6446 Fast Thinner	P852-6444 Medium Thinner									

Colour and Gloss

COLOUR MIXING and TINTING

All Tinters should be thoroughly hand stirred when first opened, and then stirred on a mixing machine for 10 minutes before use. Thereafter all tinters should be machine stirred twice a day for at least 10 minutes.

It is possible to tint P651-9006 with up to 10% of *Turbo Vision* tinters.

COLOUR CHECKING

As with all refinish paint systems, a colour check should be carried out before painting the vehicle.

GLOSS REDUCTION

It is possible to reduce the gloss level of P651-9006 direct gloss topcoat following this chart:

P651-9006 Gloss Readymix Colour Quantity (by weight)	P650-6000 MATT Binder quantity (by weight)	Activation RATIO (by volume)	GLOSS % 60°	GLOSS Description
100	-	3:1:1.5	>90	High Gloss
75	25 (*)	3:1:1.5	65-75	Semi-Gloss
50	50 (*)	3:1:1.5	30-40	Semi-Matt

Adding P650-6000 matt binder to reduce gloss level will affect opacity of the topcoat. For optimal opacity and UV protection in semi-gloss and semi-matt RAL9006, it is recommended to spray a first coat of RAL7001 Silver Grey solid colour before spraying 2 coats of direct gloss metallic colour.

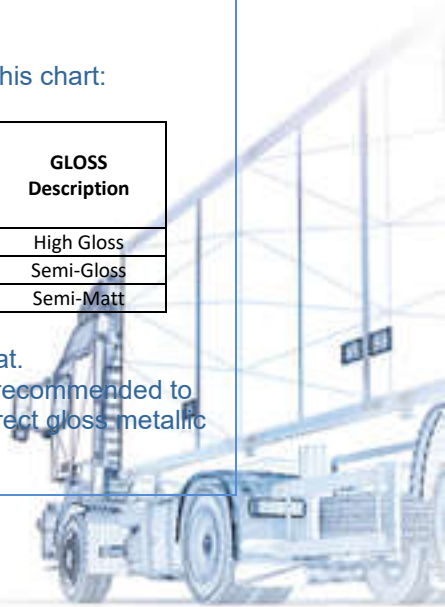

TURBO VISION[®]

General Process Notes

RECOAT

TURBO VISION[®] P651-9006 Topcoat can be recoated by itself within 8 hours without sanding. If baked, or air-dried longer than 8 hours, the topcoat should be sanded before recoating. P651-9006 does not normally require application of a clearcoat, but if a clearcoat is required, use P190-1400 according to these recoat instructions.

DECAL APPLICATION

It is recommended that TURBO VISION[®] RAL9006 Aluminium Ready Mix Topcoat is allowed to cure for at least one week at 20°C prior to any decal application.

COVERAGE

Approximately 6 to 8 m² per litre of ready for use paint at a dry film thickness of 50 microns depending on thinning ratio used.

OTHER POINTS TO NOTE

Allow finishes to harden thoroughly before subjecting to vehicle washes. This can take a number of weeks if vehicles are air-dried in cold conditions and/or paint film thickness is excessively high.

STORAGE

Mixing Room Temperature:

Store P600-xxxx Tinters and P651-xxx products in the Mixing Room between the following temperatures: 18 to 25°C.

Storage Temperature:

Store P600-xxxx Tinters and P651-xxx products between the following temperatures: 5 to 35°C (41 to 95°F).

Store in accordance with local regulations. Store in original container protected from direct sunlight in a dry, cool and well-ventilated area, away from incompatible materials and food and drink. Keep container tightly closed and sealed until ready for use.

Containers that have been opened must be carefully resealed and kept upright to prevent leakage. Do not store in unlabelled containers.

Use appropriate containment to avoid environmental contamination.

Always refer to the material Safety Data Sheet.

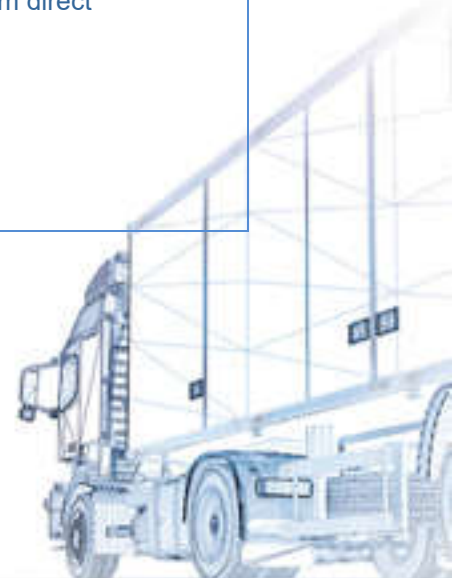

TURBO VISION[®]

VOC INFORMATION

The EU limit value for this product (Special Finishes: IIB.e) in ready to use form is max. 840g/litre of VOC.

The VOC content of this product in ready to use form is max. 493 g/litre.

Depending on the chosen mode of use, the actual ready to use VOC of this product may be lower than that specified by the EU Directive code.

These products are for professional use only, and are not to be used for purposes other than those specified. The information on this TDS is based on present scientific and technical knowledge, and it is the responsibility of the user to take all necessary steps in order to ensure the suitability of the product for the intended purpose.

For Health and Safety information please refer to the material Safety Data Sheet, also available at: http://www.ppg.com/Autocolor_MSDS

For further information please contact:

Customer Service Sales Group
PPG Industries (UK) Ltd
Needham Road
Stowmarket
Suffolk IP14 2AD

Tel: 01449 771771

Fax: 01449 773472

